



RDL®

High Performance Audio Products. Made in America.

TWISTED PAIR FORMAT-A



Models D-TPSM2A, DS-TPSM2A, DB-TPSM2A Active Two-Pair Sender Dual Microphone Preamp

- Two Balanced Microphone XLR Inputs with P48 Phantom
- Switch-Selectable Mic Gain on Side Panel
- Gain Selector Provides Fixed 40 dB, 60 dB or Automatic
- Automatic Gain: 60 dB for Dynamic Mics; 40 dB for Condenser Mics
- Output Pair Selector to Feed RJ45 Pair (A, B or C) for Each Preamp
- Signal and Power Pairs Pass Through RJ45 Connectors
- Module is Remotely Powered Through RJ45 Connector
- Utilizes Two Format-A Pairs
- Daisy-Chain with a Single-Pair Format-A Sender
- Studio-Quality Precision Active Balanced Circuitry

The D SERIES-TPSM2A modules are two-pair audio sending modules compatible with RDL Format-A twisted pair products. These modules are designed to be mounted in wall boxes, cabinets or other enclosures that allow users to connect audio sources. The -TPSM2A models mount in RDL WB-1U and WB-2U wall boxes, or in standard U.S. electrical boxes. The D-TPSM2A features a white front-panel laminate with gray lettering that matches RDL Decora®-style remote controls. The DB-TPSM2A features a black front-panel laminate. The DS-TPSM2A is constructed of stainless steel to coordinate with RDL Decora-style stainless steel remote controls in commercial/industrial installations.

APPLICATION: The D SERIES-TPSM2A modules feature two XLR microphone inputs. The module provides IEC 48 V phantom (P48) and accepts input signals from both dynamic and condenser microphones. The input signals are amplified using studio-quality microphone preamplifiers optimized for normal operating levels. The rear-panel GAIN switch is normally set by the installer for AUTO (automatic) gain. The module automatically sets the gain to 60 dB for dynamic microphones or 40 dB for condenser microphones. If consistently low mic levels are expected, this switch may be set to the HIGH gain position. If the module is used only with condenser microphones, the switch may be set to LOW gain. Each pre-amplified microphone source is routed to one output cable pair selected during installation using a rear-panel switch.

These modules drive only two cable pairs, therefore they accept a signal and power from another mic-level or line-level Format-A sender. The D SERIES-TPSM2A modules have a second RJ45 jack for that input cable. One single-pair sender may be chained with the -TPSM2A. If two senders are connected together, each audio source must feed a different pair: A, B or C. The power pair and all three audio pairs are fed through both rear-panel RJ45 jacks.

The D SERIES-TPSM2A must be remotely powered through the twisted pair cable from any other module, signal distributor or RDL power inserter connected to the same twisted pair cable.

RDL FORMAT-A features superior audio performance that rivals or exceeds shielded wiring. Design simplicity, ease of installation, unsurpassed flexibility, automatic fused power, exceptional hum rejection, low noise, and low distortion provide designers and installers the optimum choice in economical twisted pair products.



RDL[®]

High Performance Audio Products. Made in America.

FORMAT-A TWISTED PAIR Models D-TPSM2A, DB-TPSM2A, DS-TPSM2A Format-A Two-Pair Senders

Installation/Operation

CE Declaration of Conformity available from rdlnet.com.
Sole EMC specifications provided on product package.
Specifications are subject to change without notice.

- STEP 1:** Set the pair selection switch for each pre-amp to pair A, B or C to select the pair that will be driven. Each pre-amp must be set to a different pair.
No other connected sender module can be set to either pair being used by the -TPSM2A.
- STEP 2:** Set the GAIN switch for AUTO, HI or LO gain.
- STEP 3:** Connect the twisted pair cable(s) and fasten the module in its mounting box.

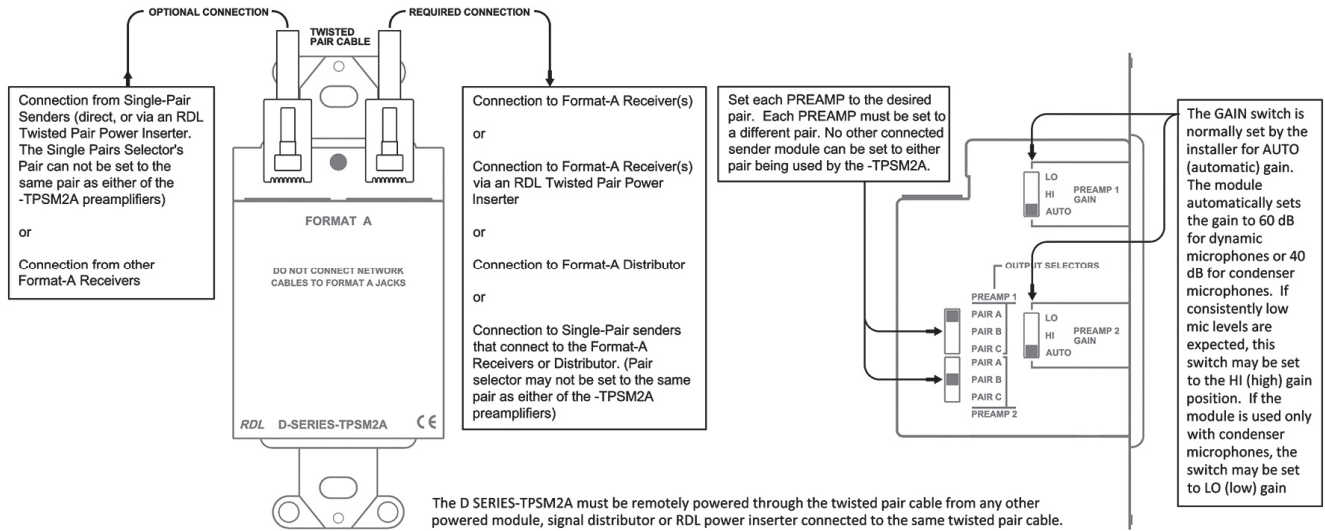

RJ45 Standard wiring

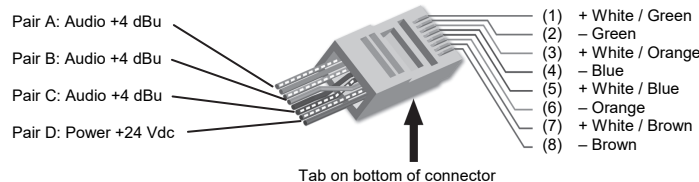

RJ45 conductor colors shown are for 568A standard. The 568B standard may be used if the connectors at both ends of the cable are wired identically.

TYPICAL PERFORMANCE

Inputs (2):	XLR (3 pin, 1=GND, 2+, 3-)
Gain (fixed):	40 dB (LOW gain); 60 dB (HIGH gain)
Gain (AUTO):	40 dB for condenser mics; 60 dB for dynamic mics
Maximum Input Level:	>-18 dBu (LOW gain); >-35 dBu (HIGH gain)
Input Impedance:	> 1 k Ω balanced
Phantom Power:	48 (48 V per IEC 61938: 2013)
Output:	RDL TP Format A
Format-A Signal Pair Used:	Switch-selectable A, B, or C (rear panel; one switch for each preamplifier)
Headroom (above +4 dBu output):	>18 dB
Channels:	2 (1 and 2; may be used for stereo or as two separate mono preamplifiers)
Gain Selectors (2):	LOW, HIGH or AUTO (rear panel; one for each preamplifier)
Frequency Response:	20 Hz to 20 kHz (+/- 0.5 dB)
THD:	< 0.05%
CMRR:	> 80 dB (20 Hz to 5 kHz)
Residual Noise (below +4 dBu output):	< -85 dB (20 Hz to 20 kHz, 40 dB gain, 150 Ω source) < -70 dB (20 Hz to 20 kHz, 60 dB gain, 150 Ω source)
Crosstalk:	< -70 dB (20 Hz to 15 kHz, 60 dB gain, 150 Ω sources)
Power Requirement:	24 Vdc @ 80 mA (120 mA with phantom), Ground-referenced

Radio Design Labs Technical Support Centers