



# RDL®

High Performance Audio Products. Made in America.

## TWISTED PAIR FORMAT-A



### Models D-TPSL2A, DS-TPSL2A, DB-TPSL2A Active Two-Pair Sender XLR Microphone & Stereo RCA In

- Balanced Microphone XLR Input with Phantom
- Switch-Selectable Mic Gain on Rear Panel
- Two Unbalanced -10 dBV Phono Jack Line Inputs
- MIC Feeds Pair A; L and R Summed to Mono Feed Pair B
- Remote Powering through Twisted Pair Cable
- Fused Local Power Feeds all Connected Modules
- Local Power Input on Terminal Block
- Blue LED Indicates Module is Powered
- Utilizes Two Format-A Pairs
- Studio-Quality Precision Active Balanced Circuitry

The D SERIES-TPSL2A modules are two-pair audio sending modules compatible with RDL Format-A twisted pair products. These modules are designed to be mounted in wall boxes, cabinets or other enclosures that allow users to connect audio sources.

**APPLICATION:** The -TPSL2A modules feature an XLR microphone input and two RCA phono jack inputs summed to mono. The unbalanced inputs are designed to receive standard -10 dBV consumer level signals. The microphone input provides 24 Vdc IEC phantom voltage and accepts both dynamic and condenser microphone signals. The input signals are amplified using studio-quality preamplifiers optimized for normal operating levels. A rear-panel GAIN switch is provided to set the amplification of the microphone preamplifier. This switch is normally set by the installer for NORM (normal) gain. If consistently low mic levels are expected, this switch may be set to the HIGH gain position. The pre-amplified microphone source is routed to pair A. The summed left and right line-level inputs are routed to output cable pair B.

These modules drive only two cable pairs, therefore they accept a signal and power from one mic-level or line-level Format-A single-pair sender. One single-pair sender may be chained with the -TPSL2A. A single-pair sender must be set to feed pair C if it is connected together with the -TPSL2A. The power pair and all three audio pairs are fed through both rear-panel RJ45 jacks.

The -TPSL2A may be powered directly from a 24 Vdc power supply using the detachable terminal block. Local power connected to the module is also fed to all connected remote modules. The -TPSL2A may be remotely powered through the twisted pair cable from any other module, signal distributor or RDL power inserter connected to the same twisted pair cable. Module power is indicated by a front-panel LED.

RDL FORMAT-A features superior audio performance that rivals or exceeds shielded wiring. Design simplicity, ease of installation, unsurpassed flexibility, automatic fused power, exceptional hum rejection, low noise, and low distortion provide designers and installers the optimum choice in economical twisted pair products.



# RDL®

High Performance Audio Products. Made in America.

## FORMAT-A TWISTED PAIR Models D-TPSL2A, DB-TPSL2A, DS-TPSL2A Format-A Two-Pair Senders

## Installation/Operation

**CE** Declaration of Conformity available from [rdlnet.com](http://rdlnet.com).  
Sole EMC specifications provided on product package.  
Specifications are subject to change without notice.

**STEP 1:** Set the MIC gain switch to NORM (normal gain) unless consistently low mic level signals are expected. Set the MIC gain switch to HIGH if low levels are always expected. Note: If both normal and low level mic signals are expected, the gain should be set to NORM to avoid clipping when high levels are connected. The pre-amplified microphone source is routed to pair A. The summed left and right line-level inputs are routed to output cable pair B. A single-pair sender must be set to feed pair C if it is connected together with the -TPSL2A.

**STEP 2:** Connect 24 Vdc to the power input terminals if this module is not being powered through the twisted pair cable from another module, or if this module is located an excessive distance from the next powered module on the cable. Note: The front-panel power LED will be illuminated if this module is powered. If this module is powering other modules through the cable and if there is a wiring short, the short must be cleared then power must be turned off to this module for 10 seconds to reset the internal protection circuit.

**STEP 3:** Connect the twisted pair cable(s) and fasten the module in its mounting box.

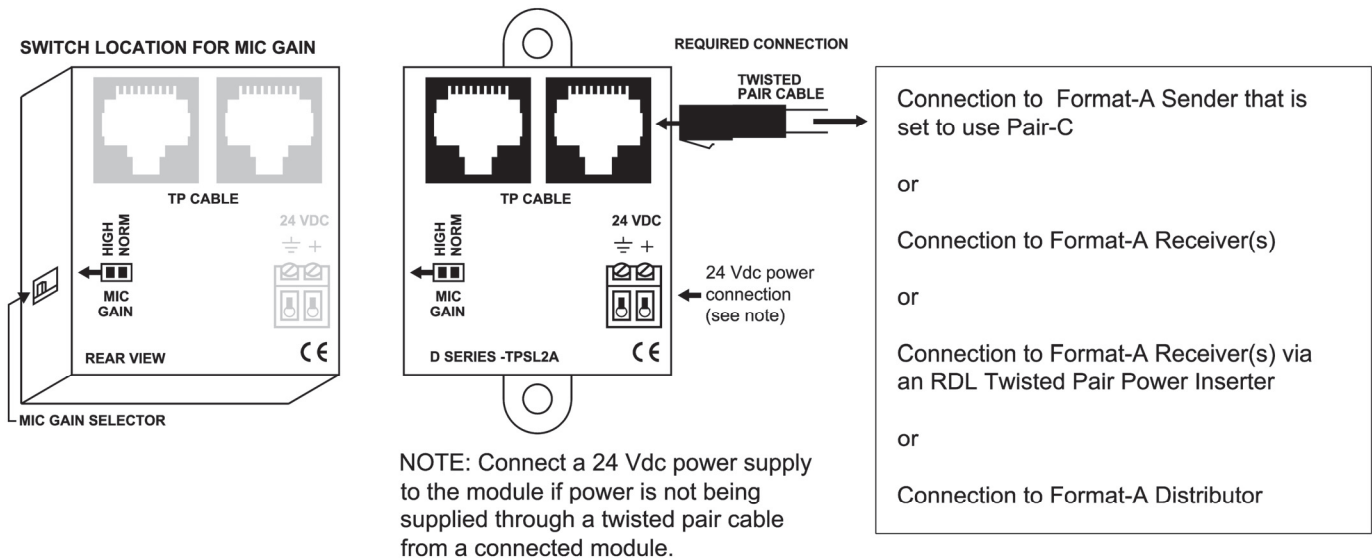

### RJ45 Standard wiring

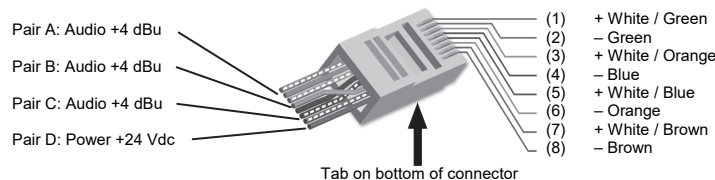

RJ45 conductor colors shown are for 568A standard. The 568B standard may be used if the connectors at both ends of the cable are wired identically.

### TYPICAL PERFORMANCE

Input Connection: Mic: XLR; Line: RCA Phono  
 Input Level: Mic: -45 to -65 dBu Balanced; Maximum: -40 dBu (HIGH Gain), -28 dBu (NORM Gain); Line: -10 dBV Unbal.; +8 dBV Max  
 Format-A Signal Pairs Used (2): A (Mic); B (Unbal Line inputs, summed to mono)  
 Gain: Mic: 50 dB (NORM) or 63 dB (HIGH), Switch-selectable on rear panel; Line: 12 dB RDL TP Format-A  
 Output: RJ45  
 Output Connection: Mic: 100 Hz to 30 kHz (+/- 1 dB); integral low-cut filter -10 dB @ 30 Hz; Line: 20 Hz to 50 kHz (+/- 0.5 dB)  
 Frequency Response: Mic: < 0.1% (80 Hz to 20 kHz); Line: < 0.05% (20 Hz to 50 kHz); < 0.005% (1 kHz)  
 THD+N: Mic: < -80 dB (NORM Gain), < -70 dB (HIGH Gain); Line: < -95dB  
 Noise below +4 dBu: Mic: < -80 dB (NORM Gain), < -70 dB (HIGH Gain); Line: < -95dB

Crosstalk: Line to Line: < 90 dB (1 kHz); < 75 dB (20 Hz to 20 kHz); Line to Mic (HIGH Gain): < 65 dB (1 kHz), < 60 dB (20 Hz to 20 kHz); Line to Mic (NORM Gain): < 75 dB (1 kHz), < 70 dB (20 Hz to 20 kHz) > 18 dB  
 Headroom above +4 dBu: Mic: > 60 dB (HIGH Gain 50 Hz to 150 Hz), > 65 dB (NORM Gain 50 Hz to 150 Hz)  
 CMRR: Power In  
 Indicator: Detachable terminal block; RJ45  
 Power Connections (2): 24 Vdc @ 65 mA plus connected loads  
 Power Requirement: 1.6" (4.06 cm) W; 4.11" (10.45 cm) H; 1.89" (4.8 cm) D  
 Dimensions: 2.4" (6.1 cm)  
 Mounting Box Minimum Depth:  
 Ambient Operating Environment: 0° C to 55° C

Radio Design Labs Technical Support Centers

U.S.A. (800) 933-1780, (928) 778-3554 - Europe [NH Amsterdam-Duivendrecht] ++31 20-6238 983