



# RDL®

High Performance Audio Products. Made in America.

## Model DD SERIES-BN31 Wall-Mounted Bi-Directional Mic/Line Dante Interface 4x4

- Interfaces Four Dante Inputs and Four Dante Outputs
- One Mini-jack and Two XLR Front-Panel Inputs
- One Mini-jack Front-Panel Output; Two Outputs on Rear-Panel Terminal Block
- Converts Two Standard XLR Mic or Line Audio Sources to Dante Network Channels
- Each XLR Input is Switch Selectable for Mic or Line
- Studio Quality Low-Noise Microphone Preamplifiers
- Switch-Selectable Mic Gain: 40 dB, 48 dB or 62 dB
- Switch-Selectable 48 V Mic Phantom (P48)
- Switch-Selectable Line Gain: Unity, 12 dB or 19 dB
- Mini-jack -10 dBV Input is Switch Selectable Stereo or Summed to Mono
- Converts Four Dante Network Audio Signals to Line Level
- Mini-jack -10 dBV Output is Switch Selectable Stereo or Mono (Left Channel)
- Rear Panel Outputs Switch Selectable Balanced +4 dBu or Unbalanced -10 dBV
- Special Software Not Required for Module Setup
- Studio Quality, Low-Noise Performance
- High Resolution 24 Bit Analog to Digital and Digital to Analog Conversion
- Legendary RDL Analog Filtering Enhances Superb Audio Performance



**APPLICATION:** The DD-BN31 is a complete wall-mounted Dante audio network interface. It features two XLR mic or line inputs, one stereo Mini-jack line input and one stereo Mini-jack line output on the front panels, plus two line outputs on a rear-panel detachable terminal block. Special software is not required to configure the DD-BN31. Each XLR input provides three switches that may be set from the front of the unit when the cover plate is not installed. One switch enables or disables P48 phantom for that input; the second switch selects the mic or line gain range; the third switch sets the gain. The Mini-jack input provides a switch to configure the input for stereo or summed mono. The Mini-jack output provides a switch to configure the output for stereo or left-channel mono. Each rear-panel output provides a switch to set the output to balanced professional or unbalanced consumer level. The DD-BN31 fits a standard US dual-gang electrical box or an RDL WB-2 back box for installations in thinner European or equivalent walls. The DD-BN31 is PoE powered, and is available in multiple finishes with optional customized graphics.

The two XLR inputs are each converted to a separate Dante network transmit channel. Three gain settings are switch-selectable for both the mic and line input ranges to match condenser or dynamic mic levels and standard line levels.

The Mini-jack left and right inputs are each converted to a separate Dante network transmit channel. Each input provides a network digital audio level of -20 dBFS for an unbalanced -10 dBV input. The input is equipped with a selector to sum the left and right Mini-jack inputs. The summed signal feeds both Dante transmit channels.

Two Dante audio channels are converted to unbalanced line level to feed the front-panel Mini-jack. Each channel provides -10 dBV unbalanced for a network digital audio level of -20 dBFS. The left and right Mini-jack channels are normally fed from Dante receive channels 3 and 4 (stereo). The Mini-jack output is equipped with a selector to feed both output channels from Dante receive channel 3 (mono). This selector may be set from the front of the unit when the cover plate is not installed.

Two Dante audio channels are converted to balanced line level on the rear-panel detachable terminal block. Each output provides +4 dBu balanced for a network digital audio level of -20 dBFS. Each output is equipped with a selector to unbalance the audio and attenuate the level to -10 dBV. These switches are located on the top of the chassis and are set by the installer prior to mounting the unit.

The rear-panel outputs are intended for connection to RDL AMS connectors mounted in Decora-style plates that match the DD-BN31. AMS audio connectors include RCA, Mini and XLR jacks. The output plate may be located together with the DD-BN31 in a triple gang box or may be mounted remotely in a single box.

Valid PoE power and synchronization to the Dante network are indicated by green LEDs visible from the front of the unit.

The DD-BN31 is a professional grade product with discrete mic preamplifiers for studio quality fidelity and low noise performance, coupled through metal XLR jacks housed in a stainless steel chassis with powder-coated or stainless steel Decora front plates.

The DD-BN31's superior performance specifications make it ideally suited to the most demanding installations, and an exceptional value in commercial networked audio systems. This full-featured product is engineered and manufactured in the U.S.A for continuous duty in demanding installations. Designed to outperform. Built to last.



# RDL®

High Performance Audio Products. Made in America.

## Model DD SERIES-BN31 Wall-Mounted Bi-Directional Mic/Line Dante Interface 4x4

## Installation/Operation

Declaration of Conformity available from rdlnet.com.  
Sole EMC specifications provided on product package.  
Specifications are subject to change without notice.

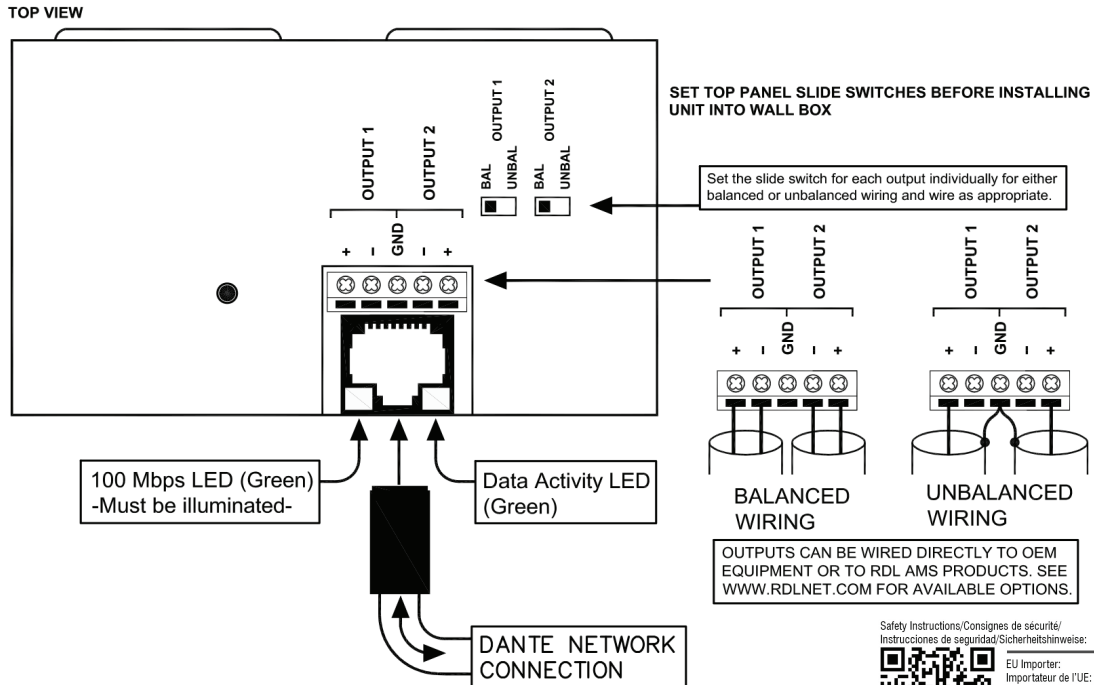
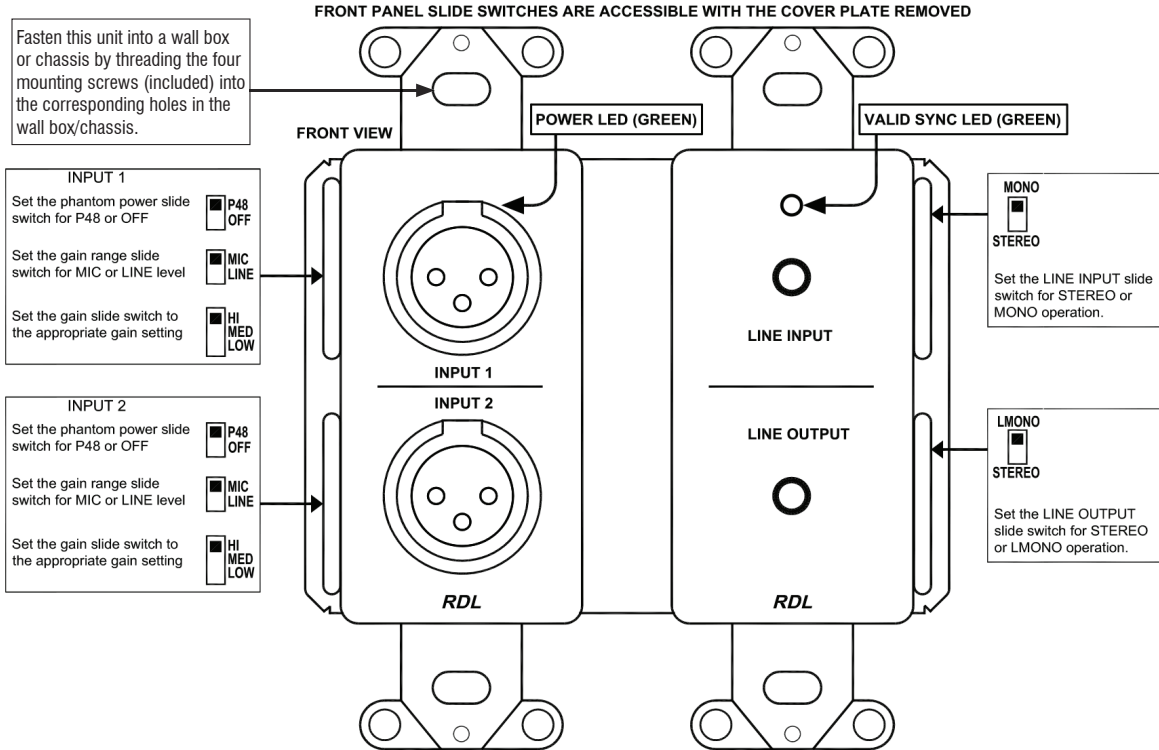

Safety Instructions/Consignes de sécurité/  
Instrucciones de seguridad/Sicherheitshinweise:



EU Importer:  
Importateur de l'UE:  
Importador de la UE:  
EU-Importeur:  
RDL Europe B.V.  
Joan Muyskenweg 124  
1114 AN Amsterdam



# RDL®

High Performance Audio Products. Made in America.

## Model DD SERIES-BN31 Wall-Mounted Bi-Directional Mic/Line Dante Interface 4x4

### TYPICAL PERFORMANCE

Network Connector:	RJ45 with Link and Speed indicators
Digital Audio Ethernet Protocol:	Dante
Transmission Rate:	100 Mbps
Sample Rates Supported:	44.1 kHz, 48 kHz (default)
Bit Depth Supported:	24 bits
Audio Operating Level:	-20 dBFS = +4 dBu
Reference Level:	0 dBFS = +24 dBu
<u>Mic/Line Inputs to Network Interface</u>	
Inputs (2):	XLR (female)
Gain:	Mic: 40 dB (LO), 48 dB (MED), 62 dB (HI); Line: Unity (LO), 8 dB (MED), 19 dB (HI)
Input Level (for +4 dBu/-20 dBFS):	Mic: -36 dBu (LO), -44 dBu (MED), -58 dBu (HI); Line: +4 dBu (LO), -8 dBu (MED), -15 dBu (HI)
Input Level (maximum):	Mic: -16 dBu (LO), -24 dBu (MED), -38 dBu (HI); Line: +24 dBu (LO), +12 dBu (MED), +5 dBu (HI)
Input Impedance:	> 2.5 kΩ (MIC); > 5 kΩ (LINE)
Phantom Power:	P48, 48 Vdc, switch-selectable
Standard for Phantom:	IEC 61938: 2013
Selectors per input (3):	Phantom, Mic/Line, Gain
Frequency Response:	20 Hz to 20 kHz (± 0.5 dB)
Equivalent Input Noise:	-130 dBu (62 dB gain); -132 dBu A-Weighted
Noise below -20 dBFS (20 to 20 kHz):	Mic: < -72 dB (LO), < -72 dB (MED), < -68 dB (HI); Line: < -72 dB (LO), < -72 dB (MED), < -70 dB (HI)
THD+N:	< 0.1% (20 Hz to 20 kHz, +4 dBu/-20 dBFS); 0.015% at 1 kHz (typ)
CMRR:	> 65 dB (50 Hz to 120 Hz)
Crosstalk:	Below Noise Floor (20 Hz to 20 kHz at operating level, any input to any input, max. mic gain)
Headroom:	20 dB

### Line Inputs to Network Interface

Inputs (2):	Mini-jack Stereo (2, L and R)
Input Level (for +4 dBu/-20 dBFS):	-10 dBV nominal
Input Level (maximum):	+10 dBV

### Equivalent Gain Settings for Dante Products

Digital signal levels in a Dante network are measured in dBFS (dB referenced to the maximum output or clipping level). The nominal standard reference level used in professional audio products is: 0 dBFS = +24 dBu. A normal operating level of +4 dBu results from a digital level of -20 dBFS.

Some OEM industry products do not specify their reference and use a non-standard reference, such as 0 dBFS = +2 dBu. Gain definitions for such products do not equate to standard levels. An operating level of -18 dBu results from a digital level of -20 dBFS. For these OEM products, 22 dB must be added to the specified levels (gain, noise floor, etc.) to normalize their specs to be equivalent to those of professional audio products.

The following table helps designers specify functionally equivalent gain settings between products using the two references described above. Installers can use this table to determine the correct switch settings on an RDL Decora module if system specifications are provided for the non-standard dBFS/dBu reference.

<b>Non-Standard Reference Products (OEM)</b>		<b>RDL Dante Decora Products</b>		
Reference: 0 dBFS = +2 dBu		Reference: 0 dBFS = +24 dBu		
Gain Setting	← Equivalent →	Gain Setting	Mic/Line Switch	Gain Switch
-18 dB		Unity*	LINE	LO
---		8 dB	LINE	MED
-3 dB		19 dB	LINE	HI
---		40 dB	MIC	LO
25 dB		48 dB	MIC	MED
40 dB		62 dB	MIC	HI

\*Unity gain on RDL products is 4 dB less than corresponding "OEM" gain in order to provide full headroom for +4 dBu balanced inputs.

In the table, microphone gain set to "40 dB" on the OEM product will produce the same digital audio level as microphone gain set to "62 dB" on the RDL product and on all industry products using the standard reference 0 dBFS = +24 dBu (-20 dBFS = +4 dBu).

The table is based on the "dBFS to dBu" references shown. OEM products may use a different reference, requiring a value other than 22 dBu be added to their gain, noise and other level specifications for performance comparison to professional audio products. Levels given are nominal, ± 1 dB.

This product is not specified to provide basic insulation from network cabling not installed wholly within the same building structure or terminated on equipment earthed to a different earthing network.

Input Impedance:	> 50 kΩ
Selectors:	Stereo (L and R)/Mono (summed)
Frequency Response:	20 Hz to 20 kHz (± 0.2 dB)
Noise below -20 dBFS (20 to 20 kHz):	< -85 dB
Crosstalk:	< -85 dB (1 kHz); < -65 dB (L into R, R into L, 20 Hz to 20 kHz)
THD+N:	< 0.05% (20 Hz to 20 kHz, +4 dBu/-20 dBFS); 0.01% at 1 kHz (typ)
Headroom:	20 dB
<u>Network to Line Outputs</u>	
Outputs (4):	Balanced, detachable terminal block (2); Unbalanced, Mini-jack (2, L and R)
Output Level (operating):	+4 dBu (nominal) balanced; -10 dBV unbalanced
Output Level (maximum):	+24 dBu balanced; +10 dBV unbalanced
Output Impedance:	150 Ω balanced; 500 Ω unbalanced
Frequency Response:	20 Hz to 20 kHz (± 0.5 dB)
THD+N:	< 0.1%
THD:	< .01% (1 kHz)
Noise:	< -78 dB (bal., below +4 dBu); < -98 dB (bal., below +24 dBu); < -75 dB (unbal., below -10 dBV)
Crosstalk:	Below Noise Floor (1 kHz); < -60 dB (bal., 20 Hz to 20 kHz); < -80 dB (unbal., 1 kHz); < -70 dB (unbal., 20 Hz to 20 kHz)
Headroom above +4 dBu or -10 dBV:	20 dB
Indicators (4):	Ethernet Link and Speed (2, rear panel); Sync and Power (2, front panel)
Ambient Operating Environment:	0° C to 40° C; 30° C maximum recommended
Power Requirement:	PoE Class 0, IEEE 802.3af
Specification Conditions:	Gain/Level: ± 1 dB; Source termination: 150 Ω; A to D values measured in digital domain
Dimensions:	3.52" (8.94 cm) W; 4.11" (10.44 cm) H; 2.09" (5.31 cm) D
Mounting:	Wall mount in North American dual electrical box (4 square deep recommended) or RDL WB-2U (international wall box) at elevation ≤ 2 m.